

Firefly User's Manual for the "OASIS" G31 & 4V/450AH

August 2021



Congratulations on your purchase of a Firefly Oasis Battery!

The Firefly batteries use a patented carbon Microcell Foam grid structure that is highly resistant to sulfation and grid corrosion. They have the longest life of any lead acid battery used for deep cycling, even at extreme temperatures and operation at less than full charge.

The Firefly batteries have many advantages over a traditional lead acid battery:

- Plate corrosion is inhibited.
- Plates are resistant to sulfation.
- The high plate porosity allows the electrolyte to reach more efficiently.

Please read through this entire manual. Failure to follow installation and charging instructions will void the warranty.

Receiving & Refreshing Charge

- Check the Individual battery voltages , It will be around 12.90 V for a fully charged 12V G31 Battery and 4.30V for 4V/450AH battery.

- Freshening charge shall be carried out using a CCCV (Constant current _Constant voltage) charger as per OCV voltage observed on the batteries.
- In case the OCV (Open circuit voltage) of the battery is less than 12.30 V , the G31 battery needs to be charged @ 14.40 V (2.40 V / cell) for 12 hrs. before commissioning. · In case the OCV (Open circuit voltage) of the battery is less than 4.10 V, the 4V/450AH battery 4V 450 Ah block needs to be charged @ 4.80V (2.40 V / cell) for 12 hrs. before commissioning

Installation

MOUNTING ORIENTATION

- The 4V/450AH batteries can be installed in normal orientation or on their sides with the length (wider) side down. The G31 should be installed upright.

SPACE AND VENTILATION

- The batteries should be installed with a minimum of 0.6” between batteries to allow for proper ventilation and air circulation. If space allows, 1” between batteries is recommended for ideal operation.
- There also needs to be adequate space in the compartment for ventilation. · If possible, mount the batteries on low stand-offs to encourage air circulation around their bases.

FOLLOW ALL ABYC INSTALLATION GUIDELINES

- The batteries should be fastened securely and restrained from movement in any direction.
- The positive terminals should be protected by a cover or boots.
- Refer to ABYC standards for more installation guidelines.

PARALLEL INSTALLATION

- Ensure proper uniform current distribution with equal resistance cables on both sides of the Battery Terminals connected to common load/ charger connection points. No center tappings are allowed as it would cause differential drain on batteries in the battery bank.
- Firefly recommends no more than 4 strings of G31 or 4V450Ah to be wired in parallel. Wire the batteries with cables of equal length & resistance to a common connection point. This means that the max capacity of a bank of G31 is 464Ah at 12V (4 batteries), 24V (8 batteries), 48V (16 batteries), etc.

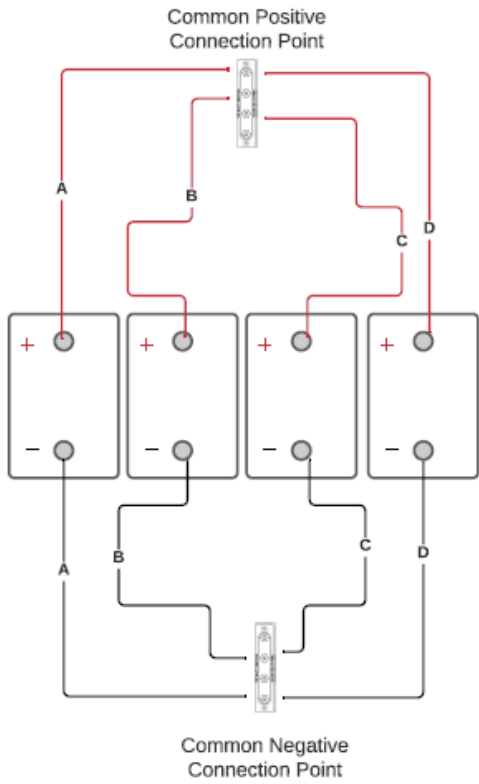

A, B, C & D are cables of equal length

SERIES INSTALLATION



4V/450Ah CONNECTION



The battery will be shipped with the connection bar shown above. This connects the 2 cells inside the module in series making the battery 4V and 450Ah. For a 12V x 450Ah bank, connect 3 x 4V/450Ah in series (3S). For 24V x 450Ah, connect 6 in series (6S). For 900Ah x 12V, it must be 3S x 2P (3 batteries in series and then parallels with the other series string). For 900Ah x 24V, it must 6S x 2P

CONNECTING THE BATTERY

- Take care not to short circuit the terminals on the battery.
- Make sure the terminals and connectors are clean and free of corrosion. ·
Connect the positive cable to the positive (+) battery terminal.
- Connect the negative cable to the negative (-) battery terminal.
- The terminals on the G31 are 3/8-16 UNC and should be torqued to 16 ft lbs.
- Do not create a bank with Firefly batteries in parallel with other manufacturer's batteries

Operation & Charging

1. Firefly batteries can be operated in a partial state of charge for long periods of time without sustaining any permanent damage but they must be charged completely and quickly, periodically to avoid suffering permanent sulfation. See statement #11 below.
2. The batteries may emit gas during the first 10-20 charge cycles. This is normal. If liquid is observed leaking from the vent caps (the smaller grey caps on the top of the battery), wipe clean with rubbing alcohol and tighten the valve cap to 1-3 Nm (0.75-2.2 ft-lbs). If leaking persists, contact your dealer. For the 4V, the gray cap can pop off and the vent can be tightened

underneath.

3. **Read through this entire section** for complete charging information. **Failure to charge according to the recommended guidelines will void the warranty.** Note that there needs to be a means to charge at a rate of 0.2C (24A for a G31) for the “Periodic Fast & Complete Charge Cycle” described below and achieving 0.4C charge current is preferred.

4. Max discharge Current: The maximum recommended discharge current is 0.7C for extended periods of time to ensure the longevity of the battery. The FF battery can discharge up to 3C for short periods.

5. Max Charge Current: The max recommended continuous charge rate is 0.5C but 1C can be tolerated for sporadic charge sessions. Frequently charging at 1C will negatively impact the battery's lifetime.

6. Peukerts Constant: If you have hardware that requires a Peukerts constant to be entered, we recommend that you do not change the factory settings due to the large inaccuracies based on varying discharge rates. The Peukerts constant for the FF battery for the 10hr and 20hr rate is 1.07. It is 1.12 for 6.5hr and 1.8hr rate. Keep in mind that whatever Peukerts correction you use, you will lose accuracy with extremely slow discharges.

7. Temperature Compensation: If you have hardware that allows the user to enter a temperature coefficient, use 24mV/C° or 13mV/F° for temperature compensation for a 12V battery & 48mV/C° or 26mV/F° for a 24V battery. This works out to 0.4mV/C° per cell. Contact us for higher voltages. The temperature compensation should be zero at an ambient temperature of 25°C/77°F. This means that for every degree the battery is ABOVE 25°C, the charge V should be reduced by 24mV/48mV for a 12V/24V system. For every degree that the battery is BELOW 25°C, the charge voltage should be increased by 24mV/48mV for a 12V/24V system. The temperature sensor can be fitted in the middle of the battery on the long side or on the positive terminal.

8. Charge V Settings: Charge the G31 to 14.4V/battery & the 4V/450AH to 4.8V/battery with temperature compensation (bulk phase) and continue charging until the charging current drops to 0.5A for the G31 or 2A for the 4V/450AH (absorption phase time will vary). You DO NOT need to fully charge the batteries each cycle in order to maintain the capacity however see the section below on periodic fast & complete charge cycle recommendations.

9. Float-Charging: For charging sources that may be charging the battery for an extended period of time (solar, or an alternator if motoring for a while); set the float voltage to 13.4V or 13.5V for the G31 and 4.5V for the 4V 450Ah model. Firefly batteries do not require a float charge on a regular basis. However, if you are float charging, due to their longer projected lifespan, it is important to keep the float voltage at 13.4V or 13.5V (4.5V for each 4V/450AH) to ensure the battery lasts for as many cycles as possible. For this reason, Firefly batteries are not recommended for applications using internally regulated alternators.

10. Reset to bulk phase: for programmable charging sources, adjust the “reset to bulk phase” to occur if the battery voltage drops below 12.0V for >1 minute for the G31 or 4.0V for >1 minute for the 4V/450AH.

11. Periodic Fast & Complete Charge Cycle Recommendations: Note that periodic fast (high current) charging from a low state of charge can help restore usable capacity after periods of repeated slow charging (less than 0.2C) or deep discharge cycles. It is recommended that the battery goes through a complete charge cycle from a low state of charge every week if they are being heavily cycled or at minimum every 30 days. Ideally the batteries will be charged at a current of 0.4C (46 Amps for an Oasis G31) but a minimum of 0.2C (24A per G31 battery) is acceptable. These charge cycles should end with a 24 hour float charge at 13.5V for the G31 and 4.5V for the 4V 450Ah model. For applications lacking fast charging capability, contact OPE or for alternative restoration procedures.

12. Operating Temperature: The optimum operating temperature for a lead-acid battery is 25°C

(77°F). As a rule of thumb, every 8-10°C (14-18°F) rise in temperature will cut the battery life in half. Note that continuous duty at elevated temperature will shorten the life of any battery. At sub zero ambient at CCCV charging, reduce the limit current to 0.1C Amps instead of 0.4C rate charging for prolonged duration.

Restoration Charge

As stated, Firefly Batteries can operate in a partial state of charge for long periods of time without sustaining any permanent damage. The usable capacity will decrease, however, with each cycle within a partial state of charge, up to a point. In order to regain the full original capacity and in some cases more, it is necessary to perform a restoration charge. To perform the restoration charge: charge the G31 to 14.4V or the 4V/450AH to 4.8V and continue to charge until the current drops to 0.5 A on the G31 or 2A on a 4V/450AH and apply a float charge of 13.5V(4.5V for 4V model) for 24 hours. Fully discharge the battery to 10.5V (G31) or 3.5V (4V/450AH), and then repeat the same charge cycle.

SOC vs OCV

State Of Charge (%) vs. Terminal Voltage (V) – G31:

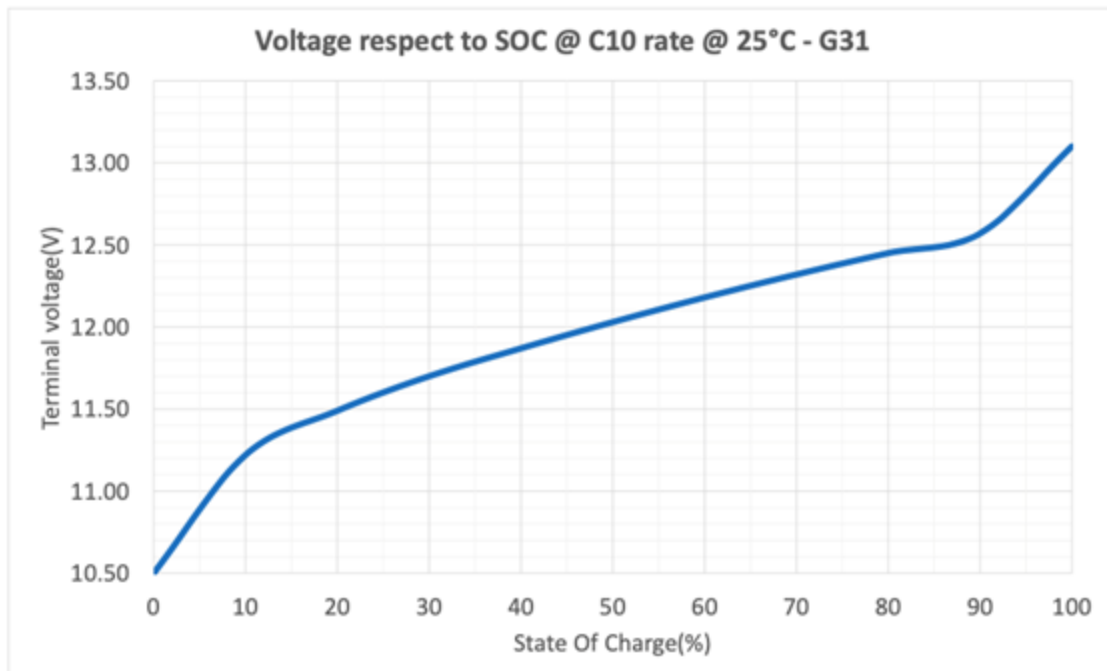

Additional Specs

Internal Resistance:

- 4V450 Ah fully charged single cell is 0.6 m.ohms max
- G31 fully charged is 3.80 m.ohms max

Please note that IR varies with SOC / DOD.

Safety

For any operation on the batteries, from storage to recycling, the following safety rules should be observed:

- Do not smoke.
- Use tools with insulated handles to tighten connections.
- Check that the connections between the cells / monoblocs are fitted correctly.
- Never place tools on the batteries (metal tools are particularly dangerous).
- Never lift the cells / monoblocs at the terminals.
- Never use a synthetic cloth or sponge to clean the cells /monoblocs.
- Use water (wet cloth) without additives.
- Avoid shocks.
- Even when disconnected, a battery remains charged.
- Always wear insulating gloves and glasses while handling batteries.
- Read the “Installation Instruction” and “Operating Instruction” carefully

EMERGENCY PROCEDURES

Battery Electrolyte Eye Contact: Immediately remove any contact lenses if present. Flush eyes with copious amounts of water from tap for at least 15 minutes. Seek medical attention immediately.

Skin Contact: Remove contaminated clothing. Flush with water for at least 15 minutes. Seek medical attention immediately.

Inhalation: Remove to fresh air. Seek medical attention immediately.

PRECAUTIONS FOR SAFE HANDLING AND USE

Steps to be taken in case of a broken battery case or electrolyte leakage: neutralize spilled electrolyte and exposed battery parts with soda ash, sodium bicarbonate, lime, etc. Do not use organic or combustible material. Wear acid resistant clothing, boots, gloves, face shield, and proper respiratory protection.

Waste Disposal Information: Please observe all federal, local, and state regulations regarding the disposal of lead/acid batteries.

Precautions to be taken in Handling, Storing, and Transportation: Store in cool, dry area away from combustible materials; store in well ventilated areas. Other Precautions: Do not charge in unventilated areas.

Shipping, storage and disposal

D.O.T. REGULATIONS-NON SPILLABLE

Firefly's Group 31 battery meets the non-spillable criteria. It is exempted from CFR 49, Subchapter C requirements, which translates to no proper shipping name, no hazardous class, no UN number, no packaging group and no hazardous labels when transporting, provided that the following criteria are met: 1. the batteries must be protected against short circuits and securely packaged. 2. The batteries and their outer packaging must be plainly and durable marked "NON- SPILLABLE" or "NON-SPILLABLE BATTERY".

SHELF LIFE

The maximum storage time at 20° C is 15 months.

The maximum storage time at 30° C is 8 months.

The maximum storage time at 40° C is 3 ~ 4 months.

Higher temperatures cause higher self-discharge and shorter storage time between recharging operations.

For extended storage periods it is recommended to check the open circuit voltage in the following intervals:

Storage at 20° C: Check Open circuit voltage after a storage period of 12 months, then every 3 months afterwards

Storage at 30° C: after a storage period of 6 months, then every 2 months afterwards.

Storage at 40° C and above : after a storage period of 3 months, then every 1 months afterwards.

FULLY-CHARGED WHEN SHIPPED

The Oasis will be shipped from the factory fully charged. Some venting from the valves is possible when it arrives.

STORAGE CONDITIONS- In the user's interest, the storage period should be as short as possible.

The temperature has an impact on the self-discharge rate and Hence, it is important to store the batteries in a fully charged condition in a cool but frost-free room.

The preferred storage temperature range is + 5 deg. C to 20 deg.C if storage room can be conditioned. If stored sub-zero, it must be stored in a charged/semi-charged state.

Storage on a pallet wrapped in plastic material is authorized. It is not recommended however in rooms where the temperature fluctuates significantly, or if high relative humidity can cause condensation under the plastic cover.

With time, this condensation can cause a whitish hydration on the poles and lead to high self discharge by leakage current. This hydration has no effect on the battery operation or service life if no corrosion occurs.

It is not recommended to stack one pallet above the other.

Avoid storing unpacked cells / monoblocs on sharp-edged supports. It is recommended to have the same storage conditions within a batch, pallet or room.

The storage location should provide the following functions:

- Shelter the cells / monoblocs from harsh weather and risk of flooding.
- Protect the batteries against any overheating risk induced by direct exposure to the sun radiation or by their amplification through glass walls.
- Protect the batteries from any risk of electric shock resulting from short circuiting by a conductive object or from a building up of conductive dust.
- Avoid any risk of mechanical shock caused by dropping objects onto the cell / monobloc or by dropping the cell / monobloc itself.

RECYCLING

There is an existing infrastructure to recycle lead acid batteries. Because Firefly's technology uses carbon, it actually decreases the amount of lead in the battery. Firefly's microcell technology can be recycled through the existing lead acid infrastructure.