



SPIRIT 1.0 Plus USER MANUAL

May, 2020 Version 2.3

Copyright © 2014-2020 ePropulsion. All Rights Reserved

Acknowledgement

Thanks for choosing ePropulsion products, your trust and support in our company are sincerely appreciated. We are dedicated to providing high-performance electric outboards, as well as thrusters, reliable lithium batteries and accessories.

Welcome to visit www.epropulsion.com and contact us if you have any concerns.

Using this manual

Before use of this product, please read this reference manual thoroughly to understand the correct and safe operations. By using this product, you hereby agree that you have fully read and understood all the contents of this manual. ePropulsion accepts no liability for any damage or injury caused by operations that contradict this manual.

Due to ongoing optimization of our products, ePropulsion reserves the rights of constantly adjusting the contents described in the manual. ePropulsion also reserves the intellectual property rights and industrial property rights including copyrights, patents, logos and designs, etc.

This manual is subject to update without prior notice. Please visit our website www.epropulsion.com for the latest version. If you find any discrepancy between your products and this manual, or should you have any doubts concerning the product or the manual, please visit www.epropulsion.com.

ePropulsion reserves the right of final interpretation of this manual.

This manual is multilingual, in case of any discrepancy in interpretation of different language versions, the English version shall prevail.

Symbols

The following symbols will help to acquire some key information.



Important instructions or warnings



Useful information or tips

Product Identification

Below figure indicates the position of the product label on which the serial number locates. Please record the serial number for access to maintenance or other after-sale services.

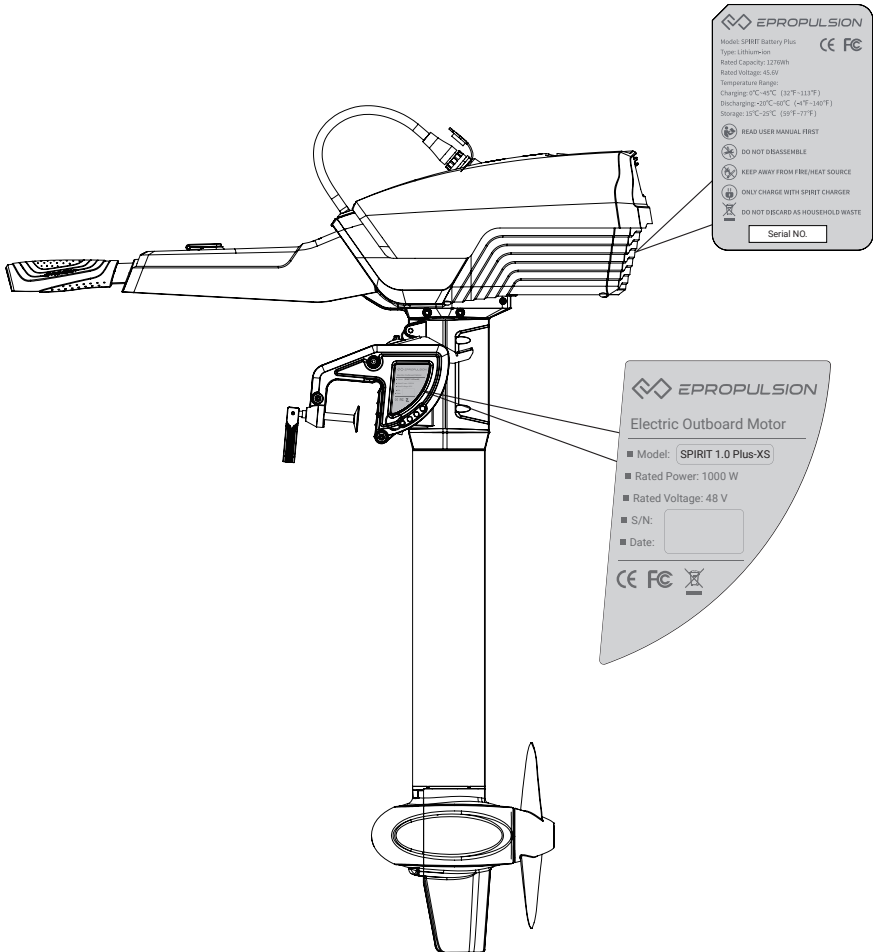

Figure 0-1

Table of content

Acknowledgement	1
Using this manual	1
Symbols	1
Product Identification	2
1 Product Overview	5
1.1 In the Package.....	5
1.2 Parts and Diagram.....	7
1.3 Specifications.....	8
1.4 Declaration of Conformity.....	11
2 Important Notes before Start	12
2.1 Outboard	12
2.2 Battery	13
3 Installation	15
4 Connecting a 48V Battery	18
5 Operation	19
5.1 Checklist before Start	19
5.2 Starting.....	19
5.3 Stopping.....	21
5.4 Power off the External Battery.....	22
5.5 Tiller Adjustment	23
5.6 Tilting up the Outboard Motor	25
5.7 Fixing the Steering Direction.....	26
5.8 Fixing for Easy Carrying	26
6 LCD Display	27
6.1 Display Introduction	27
6.2 Error Codes and Solutions	30
7 Battery Charging	32
8 Trim Angle Adjusting	34
9 Propeller Assembly	36

- 10 Anti-grounding Mode..... 37**
- 11 Maintenance 39**
 - 11.1 Notes..... 39
 - 11.2 Propeller Maintenance..... 39
 - 11.3 Replacing the Anode 40
 - 11.4 Maintenance Time Table 41
- 12 Transportation and Storage 43**
 - 12.1 Transportation 43
 - 12.2 Placement..... 44
 - 12.3 Storage..... 44
- 13 Emergency Situations 45**
 - 13.1 Impact Damage..... 45
 - 13.2 Submerged Outboard..... 45
 - 13.3 Low Battery Level 45
- 14 Warranty 46**
 - 14.1 Warranty Policies..... 46
 - 14.2 Out of Warranty 47
 - 14.3 Warranty Claim Procedures..... 47

1 Product Overview



SPIRIT 1.0 Plus is designed to be an integrated electric outboard with high overall efficiency and long cruising duration. The power of SPIRIT 1.0 Plus is equivalent to a 3hp petrol outboard but works quieter. With foldable tiller, it's easy to carry and store. All these high-performance features make SPIRIT 1.0 Plus an ideal option for tenders, dinghies and sailboats.

The SPIRIT 1.0 Plus includes three models, SPIRIT 1.0 Plus-L, SPIRIT 1.0 Plus-S and SPIRIT 1.0 Plus-XS, which have different shaft lengths for adaptation of different transom heights.

1.1 In the Package

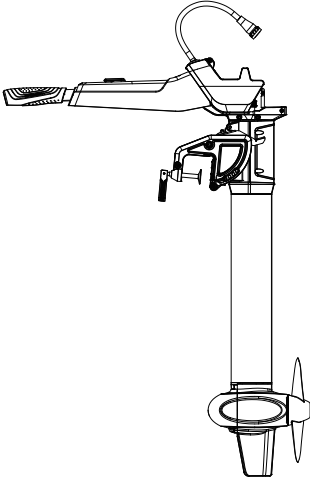
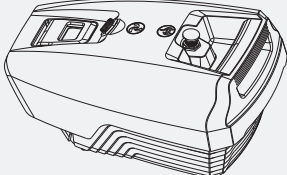
Unpack the package and check if there is any damage caused during transport. Check all the items inside the package against the below list. If there is any transport damage or lack of any listed item, please contact your dealer immediately.

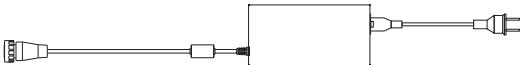
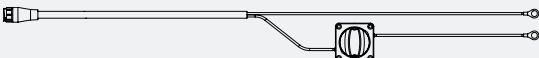
Items	Qty./Unit	Figure
Outboard (Main part)	1 set	
Battery (Purchase Separately)	1 set	

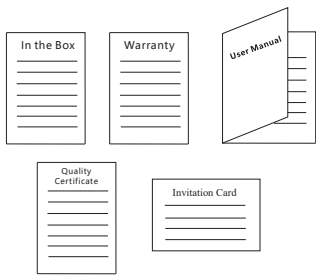
Items	Qty./Unit	Figure
Battery Charger	1 set	
Spirit External Battery Cable (Purchase Separately)	1 set	
Kill Switch	2 sets	
Steering Lock Pin	2 pcs	
In the Box, User Manual, Warranty Card, Quality Certificate & Invitation Card	1 set	



Save the ePropulsion original package for the outboard storage.



Other accessories mentioned in this user manual need to be purchased by users from ePropulsion authorized dealers.



There are currently four types of official chargers for SPIRIT Battery Plus. The one included in the package is Standard Charger. The other three are Fast Charger, Solar Charger and DC Charger, which need to be purchased separately by users from ePropulsion authorized dealers.

1.2 Parts and Diagram

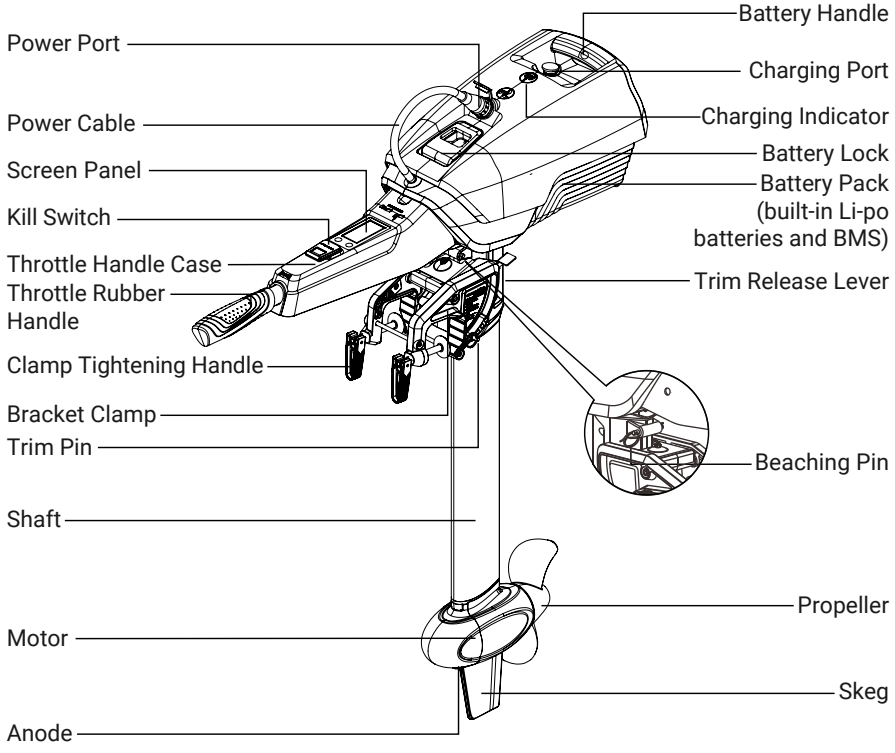

Figure 1-1

1.3 Specifications

SPIRIT 1.0 Plus-L/ SPIRIT 1.0 Plus-S / SPIRIT 1.0 Plus-XS	
Type	Electric
Rated Input Power	1 kW
Rated Current	20.8 A
Comparable Petrol Outboard	3 hp
Maximum Overall Efficiency	55%
Maximum Rotation Speed	1200 rpm
Steering	Tiller control
Weight (without battery)	10.4 kg / 22.9 lbs. (XS) 10.6 kg / 23.4 lbs. (S) 10.8 kg / 23.8 lbs. (L)
Dimension (L×W×H)	884 mm × 275 mm × 942 mm (XS) / 1042 mm (S) / 1167 mm (L) 34.8" × 10.8" × 37.1" (XS) / 41" (S) / 45.9" (L)
Shaft Length	525 mm / 20.7" (XS) 625 mm / 24.6" (S) 750 mm / 29.5" (L)
Trim Angle	0°, 7°, 14°, 21°, 70°
Propeller (Diameter / Pitch)	280 mm / 5.8"

SPIRIT Battery Plus	
Type	Lithium-Polymer
Rated Capacity	1276 Wh
Rated Voltage	45.6 V
Cut-off Voltage	33.6 V
Full Charged Voltage	52.2 V
Charging Time	~8 hrs
Cycle Life	≥500 cycles (80% of Rated Capacity)
Temperature Range	Charging: 0°C ~ 45°C (32°F ~ 113°F) Discharging: -20°C ~ 60°C (-4°F ~ 140°F)
Dimension (L×W×H)	416 mm × 275 mm × 202 mm
Weight	8.8 kg / 19.4 lbs.

External Battery Requirement	
Type	Lead-acid Battery or Lithium Battery
Rated Voltage	48 V
Minimum Voltage	39 V
Maximum Voltage	60 V
Minimum Continuous Discharge Current	28 A
Internal Resistance	< 100 mΩ

SPIRIT 1.0 Plus Charger

Output Power	180 W
Output Voltage	52.2 V DC
Output Current	3.5 A
Cut-off Current	0.4 A
Temperature Range	Operation: -10°C ~ 45°C (14°F ~ 113°F) Storage: -30°C ~ 70°C (-22°F ~ 158°F)
Rated Input Voltage	100 ~ 264 V AC
Output Frequency	50 Hz / 60 Hz
Input Current (Max)	2 A @ 220 V
Efficiency	≥ 87%

 It is forbidden to charge other batteries with SPIRIT charger. It is strictly forbidden to charge SPIRIT battery with non-official standard charger.

 SPIRIT battery plus, SPIRIT 1.0 plus machine and SPIRIT 1.0 plus charger should be used together. It is forbidden to use SPIRIT battery plus and SPIRIT 1.0 plus charger for SPIRIT 1.0 machine, and it is forbidden to use SPIRIT battery for SPIRIT 1.0 plus machine. Otherwise, the consequences of mixed use is at your charge.

1.4 Declaration of Conformity

Object of the Declaration:

Product: Electric Outboard Motor

Model: SPIRIT 1.0 Plus, SPIRIT 1.0 Plus-S, SPIRIT 1.0 Plus-L, SPIRIT 1.0 Plus-XS, SPIRIT 1.0 Plus-C

Company Name: Guangdong ePropulsion Technology Limited

Address: Room 201, Bldg.17A, 4th XinZhu Road, SongShan Lake District, Dongguan City, Guangdong Province, China

The object of the declaration is in conformity with the following directives:

- EMC Directives 2014/30/EU
- MD Directives 2006/42/EC

Applied Standards:

- EN 55014-1:2006+A1:2006+A2:2011 EN 55014-2:2015
- EN 61000-3-2:2014 EN 61000-3-3:2013
- EN 60204-1: 2016 EN ISO 12100:2010

This device complies with part 15 of the FCC Rules: Operation is subject to the following two conditions:

- (1) This device may not cause harmful interference and,
- (2) This device must accept any interference received, including interference that may cause undesired operation.

Signature: 

Shizheng Tao, Chief Executive Officer & Cofounder of Guangdong ePropulsion Technology Limited

2 Important Notes before Start

The SPIRIT 1.0 Plus electric outboard motor is designed to offer clean propulsion and excellent experience on water. For safety reasons, please read the following instructions and notes before using this product. By using this product you hereby: 1) agree to these notes and instructions; 2) agree not to use this product for purposes that infringe upon or contravene laws and regulations; 3) agree to be responsible for your own conduct while operating this product.

2.1 Outboard



- Only allow adults who have thorough understanding of this manual to operate this product.
- **Always have a paddle on board especially if the electric outboard motor is the only propulsion system.**
- Familiarize yourself with all the outboard operations, including start/stop, steering and tilting.
- Check the status of the outboard and battery level before each trip.
- Follow the boat manufacturer's instructions on the maximum allowed outboard power of your boat, do not overload the boat or the outboard.
- Take serious of battery safety. Follow battery instructions, avoid short-circuit, overheat, overcharge and over-discharge.
- Only run the outboard while the propeller is under water.
- Stop the outboard immediately if someone falls overboard.
- Do not leave the outboard in the water while the boat speed reach 35km/h.
- Tilt up the outboard above water after use.
- Wash the outboard with fresh water after operating in salt water.
- Do not leave the outboard in the water if the boat is driven by other forms of power such as sailing or rowing.
- If an error code displays and the outboard malfunctions, please reset the throttle to zero position and cut the power off, then refer to 6.2 *Error Codes and Solutions* to acquire the solution to the error.

- For protection considerations, the motor will stop immediately if the battery voltage drops below the critical level during operation or when running.
- To keep electric connectors in good condition, please spray the connectors about every 3 months with contact spray.
- To store the outboard motor, put the machine in original ePropulsion package and keep it in a dry and ventilated place without direct sun exposure.

2.2 Battery

The SPIRIT Battery Plus specially designed for SPIRIT 1.0 Plus can only be charged with an ePropulsion original charger. The battery has a built-in battery management system which provides cell balancing function, over charging protection, over discharging protection, short-circuit protection, over temperature protection, under temperature protection, over current protection, communication function, etc. Though the battery has been tested to be reliable and safe during normal operation, it should be handled with care as safety is critically important. Please adhere to the following instructions when using it.

WARNING

- Do not drop, strike or squash the battery.
- Do not disassemble the battery or conduct unauthorized repair, the battery disassembly can only be conducted by ePropulsion service.
- Never charge a broken or damaged battery.
- Only charge the battery with an ePropulsion original charger.
- Do not charge the battery near flammable materials like carpet or wood.
- Disconnect charger when not in use.
- Though the battery is IP67 waterproof, it's suggested not to immerse it in water or store it in moist environment.
- Keep conductive objects away from the discharging port and charging port to avoid damage of electronic components.
- Use the port cap to avoid accidental short-circuit.

- Never discharge the battery below 33V.
- Store the battery in dry environment.
- Charge the battery immediately after full discharge.
- Before long time storage, ensure the battery charge level is 60% around, store the battery in 15°C ~ 25°C (59°F ~ 77°F) ambient temperature. If the battery level is larger than 60% for more than ten days without activity, the battery itself will discharge with a small current around 100mA until it reaches the 60% battery level.
- Battery will actively discharge to 75% after 20 days without charging or discharging.
- If battery level is low for a long time, it will enter sleep mode. Charge to wake it up.
- During long time storage, activate the battery every 3 months by a charge condition and keep the battery charge level at 60% around. This activation is very important and it can help to keep the battery in good condition.
- After long time storage, fully charge the battery before use.
- Do not leave the battery in a hot or pressurized container, such as trunk of the vehicle on hot days.
- Dispose of unusable or damaged batteries in a container specially reserved for this purpose, follow appropriate local guideline and regulations. For further information you can contact your local solid waste collecting point or your dealer.
- Never dispose the battery as general household waste or in fire.

3 Installation

Step1: Hang the motor on the transom on the motor holder and tighten the two clamp handles.

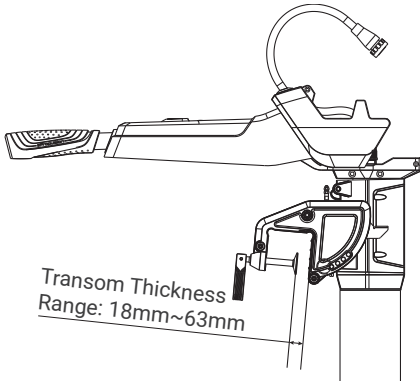

Figure 3-1

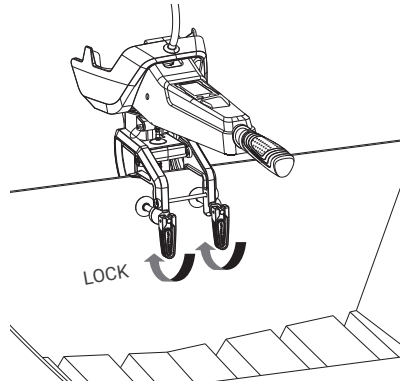

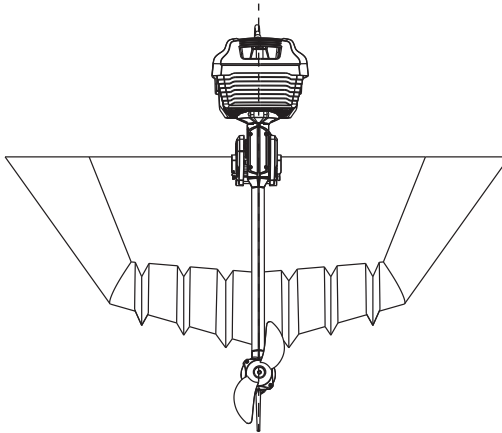

Figure 3-2

 Ensure to mount the outboard on the centerline of your boat. If the boat shape is asymmetric, please consult your dealer to get proper solution.



Center line

Figure 3-3

The mounting height of the outboard affects the running speed seriously. When the mounting height is too high, ventilation may occur to waste power. When the mounting height is too low, the water resistance will increase and it will lead to efficiency and running speed reducing. Mount the outboard and ensure the top of propeller is about 140mm below the bottom of the boat.

Transom Height / Usage Scenarios	Recommended Model
≤400mm	SPIRIT 1.0 Plus-S
400mm~600mm	SPIRIT 1.0 Plus-L
Using in shallow water or for mini boat	SPIRIT 1.0 Plus-XS

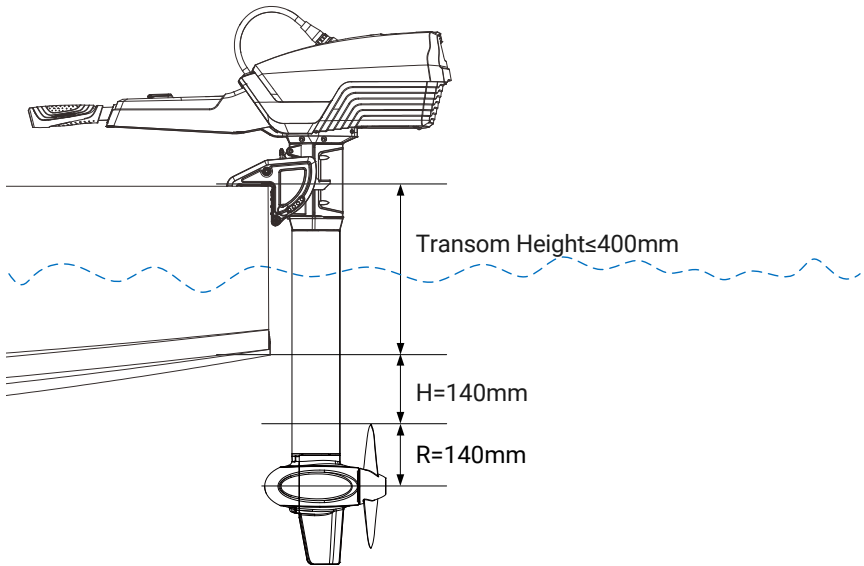

Figure 3-4

Select a proper model according to your transom height and applications. The optimum mounting height is affected by the conditions of boat and requirements. It's recommended to test running at a different height to help obtain the optimum mounting height. You can consult your dealer to get more information.

Step2: Lift the battery by gripping the handle and pull up the battery lock. Align the two slots on the battery bottom to the blocks on the bracket and put down the battery. Release the battery lock and lock the battery on the bracket.



Ensure to hold the battery handle before detaching or mounting the battery.

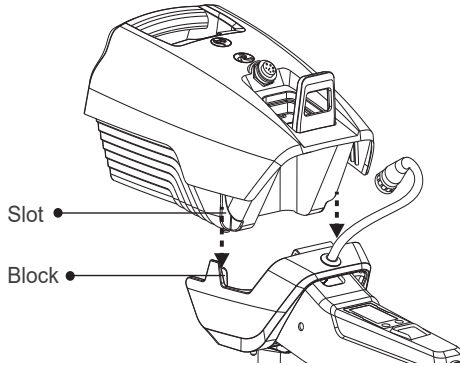

Figure 3-5

Step3: Plug the power cable in the power port and tighten the connector. The connector is metal, and it own needs to be figure tight $\frac{1}{2}$ of a turn clockwise.

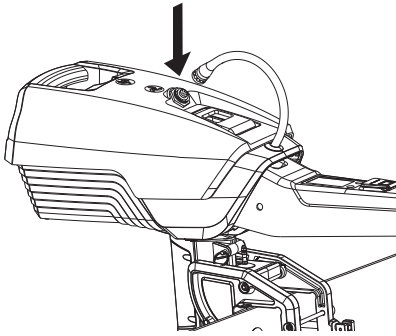

Figure 3-6

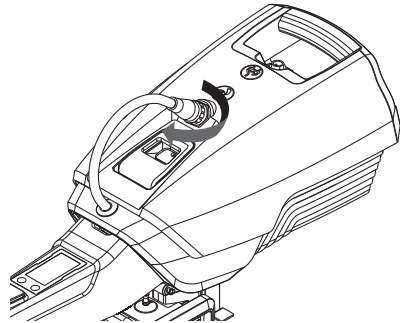



Figure 3-7

 Make sure the power cable connector and socket are dry before connecting to avoid short-circuit.

 Please spray and clean the connectors about every 3 months with contact spray.

4 Connecting a 48V Battery

When using a battery, make sure the power switch is off before connection.

- ① First connect the external battery cable to the battery.
- ② Connect the external battery cable with the power cables from the outboard.

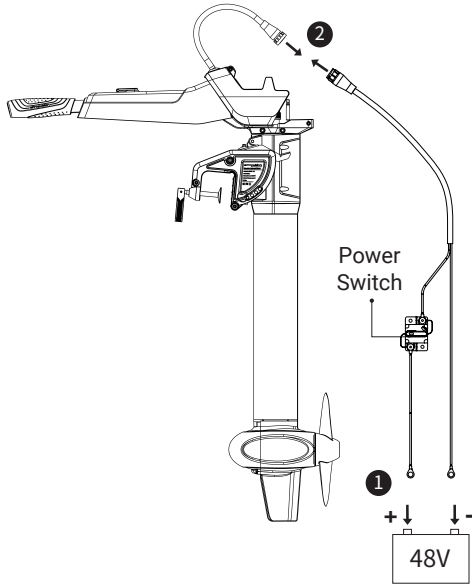



Figure 4-1

- ⚠️ Avoid battery short-circuit during connection.
- ⚠️ Outboard motor will stop working once the power cable disconnects.
- 💡 Counterclockwisely turn the reset button on the power switch until it is stuck to power on the battery before use.
- 💡 Users can also enlarge the battery capacity by connecting multiple batteries in parallel.
- 💡 During use, if a poor contact is found, it is recommended to check the tightening of each terminal connection.

5 Operation

5.1 Checklist before Start

1. Check and ensure the battery has enough power.
2. Ensure the outboard is correctly and firmly installed on the boat.
3. Ensure the propeller is correctly and firmly installed on the outboard.
4. Ensure the battery is correctly and firmly installed on the outboard.
5. Before start, check and ensure the throttle is in zero position.
6. Ensure the throttle can travel smoothly.
7. Check the connections before each trip, ensure the connections are correct and secure, no disconnection or worn or aging connections.
8. Check and ensure the power port is dry to avoid short-circuit.

 Only start the outboard when the propeller is under water.

 If the cable has been immersed in water, please dry the cable thoroughly before connection or turning on power.

5.2 Starting

Step1: Put the kill switch on the pointed position of tiller.

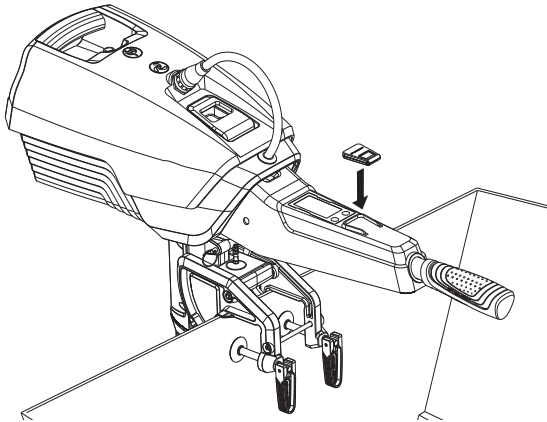

Figure 5-1

Step2: Attach the other end of the kill switch to your wrist or life vest.

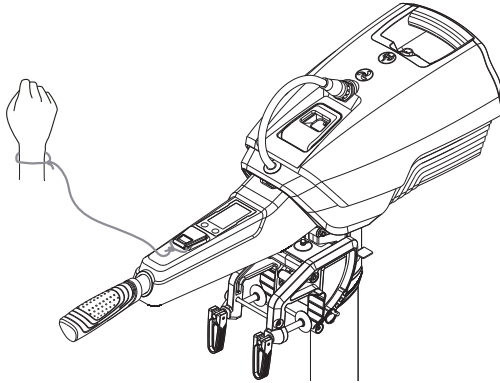

Figure 5-2

- ⚠ For safety consideration, always attach the lanyard of kill switch to your wrist or life vest, so that the outboard will be stopped in the emergency situation of falling.
- ⚠ The kill switch has magnetic field, keep it 50cm/20inch away from pacemakers and other medical implants.
- ⚠ The magnetic field of kill switch may interfere with some electronic instruments, keep it away from these electronic instruments.
- ⚠ Keep the kill switch 50cm/20inch away from magnetic cards (e.g. Credit cards) and other magnetic media.

Step3: Press and hold (≥ 2 secs) the "POWER" button to power on the system.

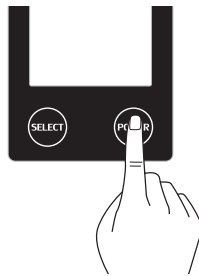

Figure 5-3

Step4: Turn the throttle from neutral position to a desired direction to start the outboard motor. Change the heading direction of the boat by turning the tiller on horizontal level.

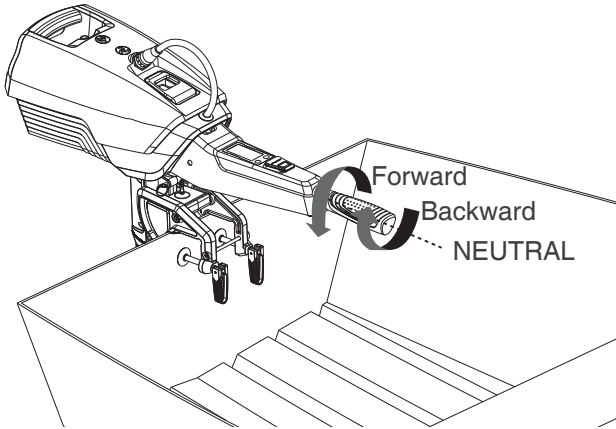

Figure 5-4

5.3 Stopping

The outboard can be stopped in one of the following four ways.

<p>NEUTRAL</p>	
<p>SELECT STOP</p>	<p>1 2</p>

• Turn throttle to neutral position.

• Remove the Kill Switch.

• Switch off the power button.

• Disconnect the power cable.

In normal operating procedure, it's recommended to stop the outboard as following steps.

1. Rotate the throttle to neutral position.
2. Wait until the outboard stops, then remove the kill switch from tiller.
3. Press and hold (≥ 2 secs) the "POWER" button to power off the system.
4. Tilt the outboard out of water and uninstall it from boat according to your requirement.

In abnormal situations like a fall over emergency, it's recommended to stop the outboard motor by removing the kill switch from the tiller.

In malfunction situations, the outboard will stop immediately for protection. The outboard will stop if one of the following situations occurs.

- 1) The throttle is in neutral position.
- 2) The power button is switched off.
- 3) The kill switch is removed.
- 4) The connection between tiller and battery is cut.
- 5) The battery is empty.
- 6) The outboard goes malfunctions (e.g. motor is blocked or the battery voltage drops below 33V).



It's recommended to tilt up the outboard out of water when the motor is not running.

5.4 Power off the External Battery

Please follow the steps below to power off the external battery.

- ① Stop the outboard (refer to 5.3 *Stopping*).
- ② Turn off the power switch.
- ③ Turn off the battery (if the battery has a switch), unplug the external battery cable.

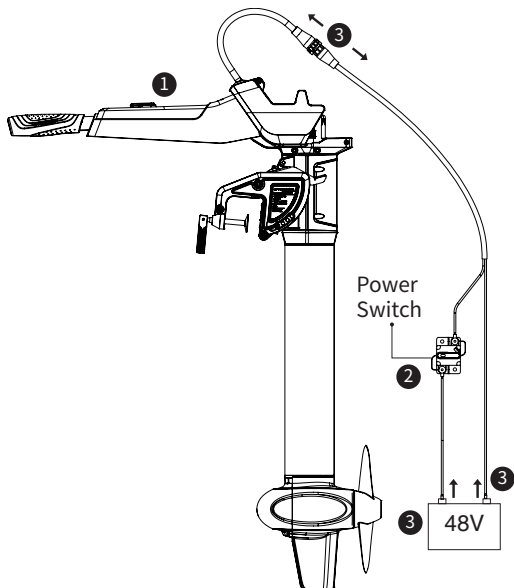

Figure 5-5

5.5 Tiller Adjustment

The tiller of SPIRIT 1.0 Plus is adjustable on both horizontal and vertical directions.

Pulling up the tiller



Pull up the tiller if necessary during operation.

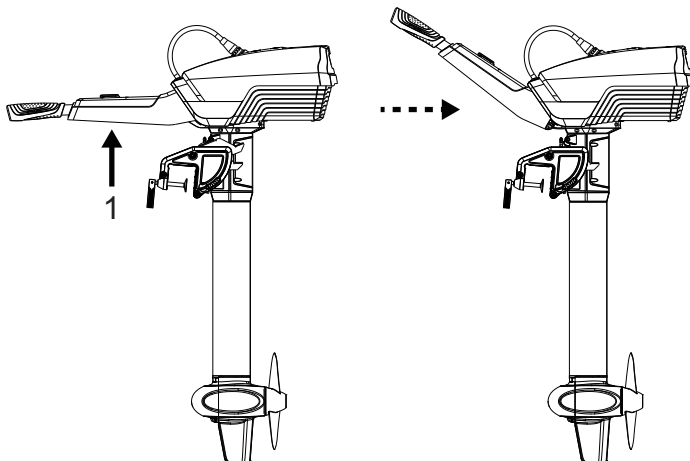

Figure 5-6

Folding the tiller

Draw the tiller along axial direction to the limit then the tiller can be folded down.

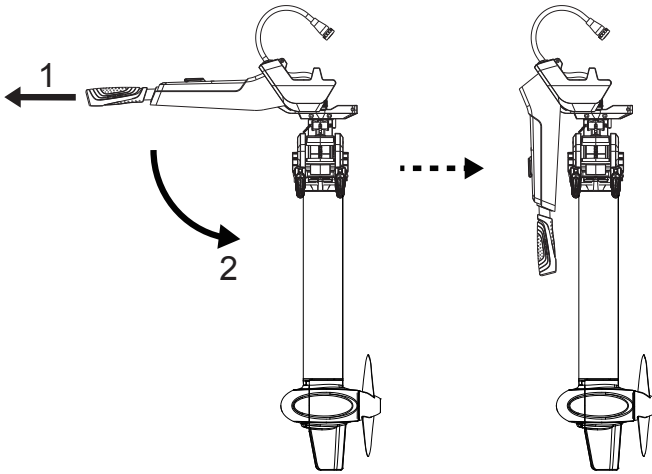



Figure 5-7

 Rotate the clamping bracket by 90° before folding down the tiller to avoid interference.

 Folding the tiller provides convenience when transporting or storing the outboard motor.

5.6 Tilting up the Outboard Motor

Toggle up the Trim Release Lever once, then take the battery handle to tilt up the outboard motor to a maximum height. After a "click" sound, release the battery handle and the outboard will stay at a position of 75° trim angle.

Hold the battery handle and toggle up the Trim Release Lever once again, users can lay down the outboard gently to the original position in water.

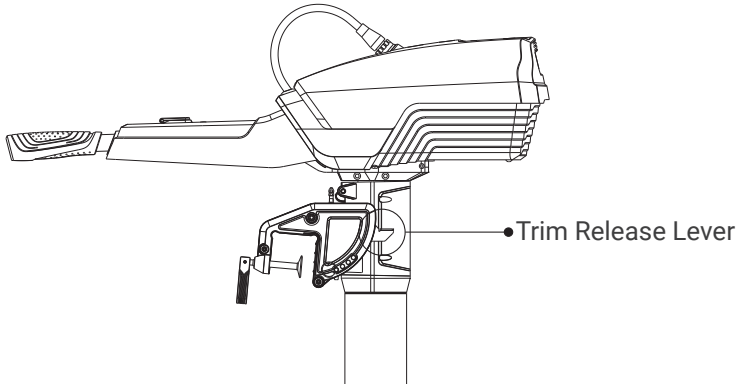

Figure 5-8

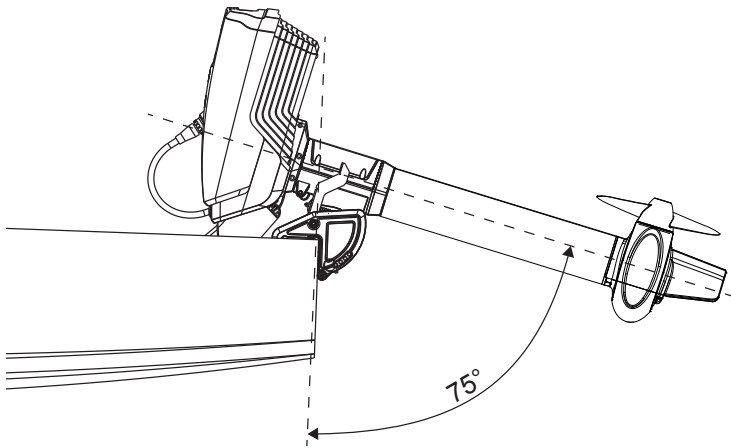

Figure 5-9

- ⚠ Never toggle the Trim Release Lever when the propeller is rotating.
- ⚠ Slight and gentle operations are recommended when tilting up and down.

5.7 Fixing the Steering Direction

Before attaching the battery, inserting the Steering Lock Pin into the hole indicated in Figure 5-10 can fix the steering direction, and the rotation of tiller on horizontal level will be disabled. Use the pin if necessary.

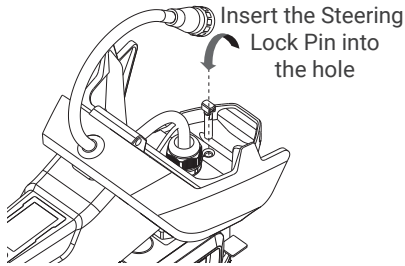

Figure 5-10

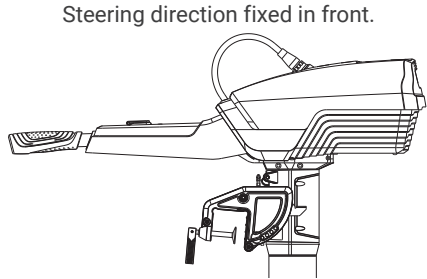

Figure 5-11

5.8 Fixing for Easy Carrying

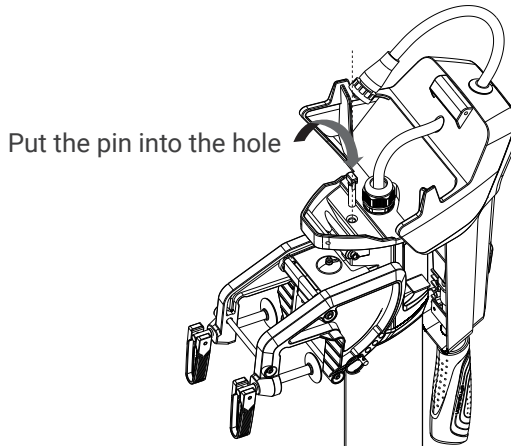

Figure 5-12

Rotate the tiller by 180° and fold to the position as indicated in Figure 5-12. Then put the lock pin into the hole to fix the folded tiller for easy carrying, storage or transportation.

6 LCD Display

The LCD display screen will display realtime status of the outboard or deliver warning messages during operation.

6.1 Display Introduction

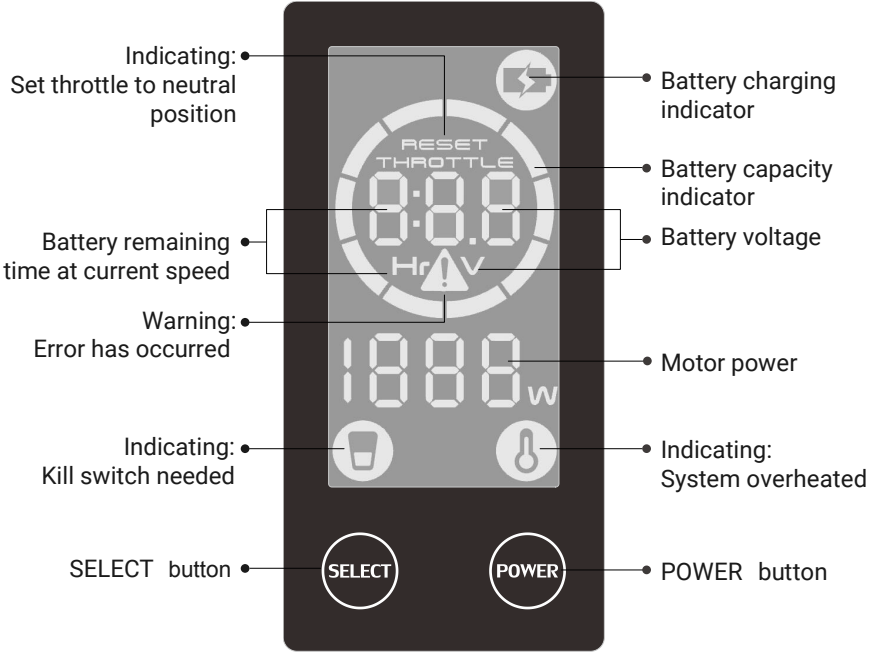













Figure 6-1

Button	Function
	In power off state, long press "POWER" button (≥ 2 secs) to power on the motor. Repeat this operation to power off.
	In power on state, press the "SELECT" button to switch the display between "Battery remaining time" and "Battery voltage". In power on state, long press "SELECT" button (≥ 10 secs) to enter throttle calibration mode.

Icon	Function
	<p>This icon will display when the battery is charging.</p> <p> This icon will display only when the input current greater than the output current.</p>
	<p>This icon shows the state of battery charge, the solid circular section indicates the percentage ratio of the residual battery. e.g.</p> <div style="text-align: center;">  <p>60% battery reserved</p> </div> <p>All the 10 blocks will be blinking when the remaining battery is less than 5%. Steer your boat to shore or wharf as soon as possible, and fully charge the battery in time.</p>
	<p>This icon will display when some error has occurred. An error code will also display. Please refer to the error codes list to troubleshoot errors. e.g.</p> <div style="text-align: center;">  <p>Error code: E01</p> </div>
	<p>This icon will display when the kill switch is removed from the tiller, which will lead to motor stop. Please attach the kill switch back.</p>

Icon	Function
	<p>This icon will display when the system is at high temperature.</p> <p> When the icon is always on, it means the driver is at high temperature.</p> <p>When the icon flashes slowly, it means the motor is at high temperature.</p> <p>When the icon flashes quickly, it means the driver and the motor are both at high temperature.</p>

6.2 Error Codes and Solutions

When the outboard is running in abnormal conditions or malfunctioning, a warning message will display with an error code. The table below will help you get a solution.

Code	Description	Solution
E01	Motor Over Voltage	Stop the motor and wait until the error message disappears. If the problem still exists, contact your dealer for repairing.
E02	Motor Over Current	Disconnect the battery and check if the motor is blocked. If not, continue driving at low speed. If this issue cannot be solved, please contact your dealer.
E03/ E04	Motor Overheating	Wait a few minutes until the motor cools down and the warning message disappears.
E05	Motor Under Voltage	Indicate the battery level is extremely low. The outboard can probably be restarted at lower speed after the message is dismissed.
E10	Motor Blocked	Disconnect the battery and remove anything that is blocking the motor. Make sure the propeller can be rotated by hand smoothly.
E20	Battery Communication Fault	Turn off the motor and reconnect the battery cable. If this issue cannot be solved, please contact your dealer.
E21	Motor Communication Fault	Turn off the motor and reconnect the battery cable. If this issue cannot be solved please contact your dealer.
E30	Throttle Calibration Required	<p>Calibration process:</p> <ol style="list-style-type: none"> 1. Press and hold "SELECT" button (≥ 10secs) until "CAL Fo" is displays. 2. Rotate the throttle forward to full power position and press "SELECT" button. "CAL ST" will display. 3. Put the throttle to zero (stop) position and press "SELECT" button. "CAL BA" will be display.

		4. Rotate the throttle backward to full power position and press "SELECT" button, the display will return to normal and the calibration is completed.
E50	Charger Fault	If you are not using an ePropulsion charger, please change an ePropulsion charger. If this condition persists, please contact your dealer.
E51	Battery Temperature Fault	Make sure the environment temperature is within 0°C to 45°C. Charging will continue when cell temperature is in that range.
E54	Battery Pack Over Voltage	Stop the motor and wait until the error message disappears. If the problem persists, contact your dealer for repair.
E55	Battery Empty	Indicating the battery is empty. The outboard can probably be restarted at lower speed after the message is dismissed.
E56	Battery Charging Over Current	Please contact your dealer.
E57	Battery Discharging Over Current	Please contact your dealer.
E58	Battery Hardware Fault	Battery has encountered serious hardware breakdown. Please replace the battery and contact your dealer.
E59	Battery Cell Fault	Battery cell fault occurs, please replace the battery and contact your dealer to repair the problematic battery.
Other	Other faults	Please contact your dealer.

 Carry out the throttle calibration procedures in strict accordance with the above sequences.

7 Battery Charging

Charge the battery when the state of battery level is low or empty. It's recommended to charge the battery after detaching it from the outboard though it's allowed to operate and charge the outboard simultaneously.

Step1: Power off the outboard first. Then disconnect the power cable and detach from the power port. Hold the handle and pull up the battery lock to detach the battery.

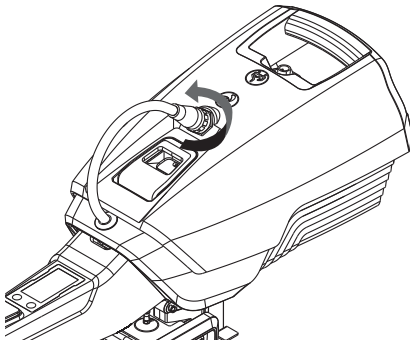

Figure 7-1

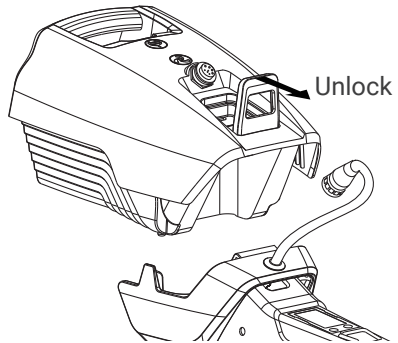

Figure 7-2

Step2: Connect the output cable of battery charger to the battery, then connect the AC power plug of the charger to the 100V~240V wall outlet.

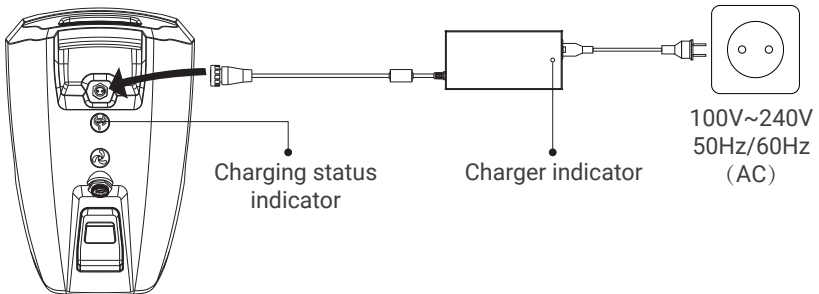

Figure 7-3

Indicator	Normal Status	Description
Charger indicator	Solid red light	The charger has been plugged into the charging port of the battery and it works well.
	Solid green light	The charger works well but has not been plugged into the charging port of the battery, or the battery has been fully charged.
Charging status indicator	Solid red light	The battery is being charged.
	Solid blue light	The battery has been fully charged.

Indicator	Abnormal Status	Description
Charger indicator	Light out	<ol style="list-style-type: none"> 1. Make sure the AC socket has power output. 2. Disconnect the battery with charger, if the charger indicator becomes solid green, there may be a fault in battery, please contact your dealer to change the battery. 3. If the charger indicator is still off after disconnecting with the battery, there may be a fault in charger, please contact your dealer.
Charging status indicator	Light out	<ol style="list-style-type: none"> 1. Make sure the AC socket has power output. 2. Disconnect the battery with charger, if the charger indicator becomes solid green, there may be a fault in battery, please contact your dealer to change the battery. 3. If the charger indicator is still off after disconnecting with the battery, there may be a fault in charger, please contact your dealer. After fixing the issues of the charger, please recheck the status of charging indicator. If there are still problems with battery, please contact your dealer.

Step3: Plug the battery charger out of the wall socket after the battery has been fully charged, then disconnect the battery charger port and charger.

8 Trim Angle Adjusting

SPIRIT 1.0 Plus has four trim angle options including 21°, 14°, 7° and 0°. The trim angle should be adjusted according to the boat type and the running speed to achieve higher efficiency. It is recommended to try different trim angles at your desired running speed to achieve the best performance.

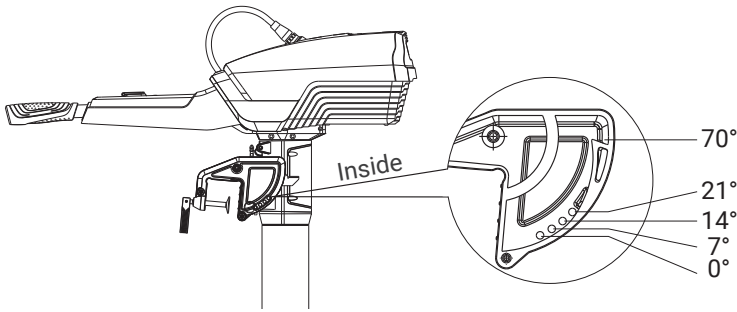

Figure 8-1

- ⚠ Only adjust the trim angle when the outboard is stopped.
- ⚠ Never toggle the Trim Release Lever if the propeller is rotating.

To adjust trim angle

Step1: Pull the trim release lever up and tilt up the outboard to the 70° position. (Users can refer to the *section 5.6 Tilting up the Outboard Motor.*)

Step2: Remove the pull ring on the trim pin and then pull the trim pin out.

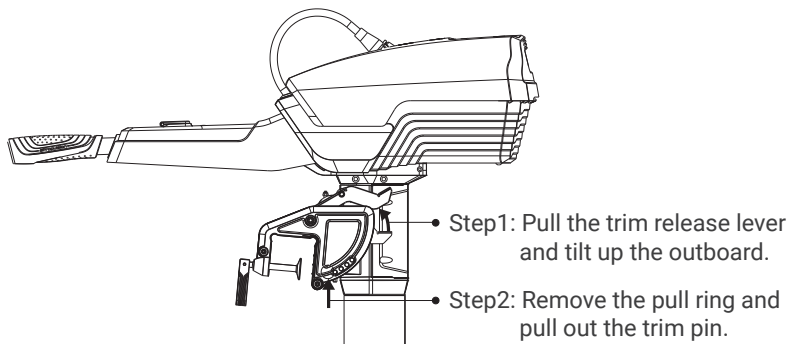

Figure 8-2

Step3: Select a desired trim angle and insert the trim pin into the corresponding position, attach the pull ring to fix the trim pin.

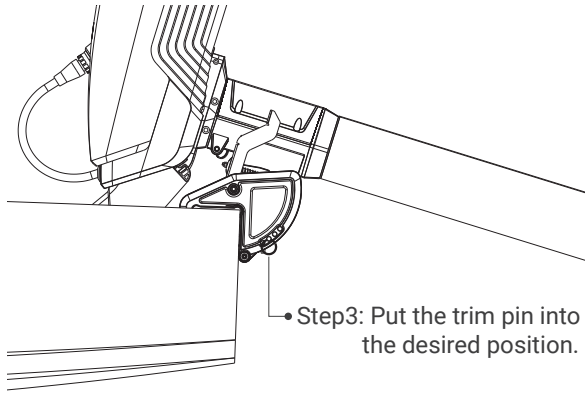

Figure 8-3

Step4: Pull the trim release lever again to lay down the outboard motor, and the outboard motor will stay at the desired trim angle.

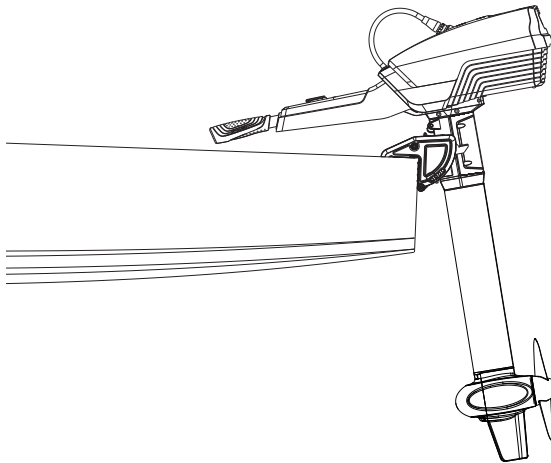

Figure 8-4

Step5: Try to tilt up the outboard and test if the angle is successfully fixed. It is recommended to try different trim angles to help find the best working trim angle for the boat and operating conditions. Please increase the speed gradually during test, watch out for water cavity and other instability problems, if the problem gets serious, stop the outboard immediately and try to reduce the trim angle.

9 Propeller Assembly

The propeller is assembled on the outboard. Before use, check the propeller and if necessary to change a new propeller, please follow instructions in Figure 9-1 to assemble a new propeller properly.

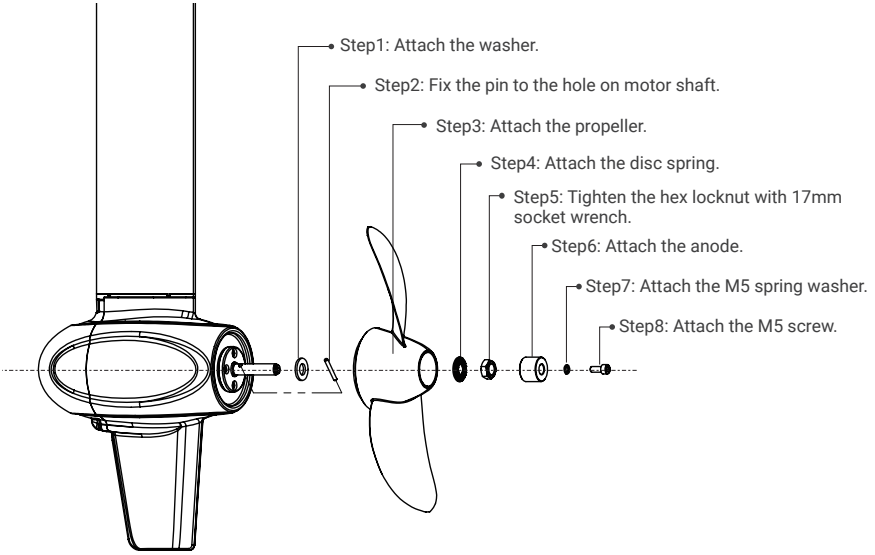

Figure 9-1

10 Anti-grounding Mode

When the boat runs in shallow water or in complicated underwater conditions, it may meet grounding dangers. Setting the outboard to anti-grounding mode will protect the outboard motor from damage if the outboard hits submerged reefs or rocks. In anti-grounding mode, the underwater part of the outboard is flexible in tilting direction and the motor will automatically tilt up if it hits something underwater.

⚠ Never turn the throttle backward when the outboard is in anti-grounding mode.

To set the outboard in anti-grounding mode:

Step1: Pull the beaching pin to the limit and hold, then pull the trim release lever to the upmost position.

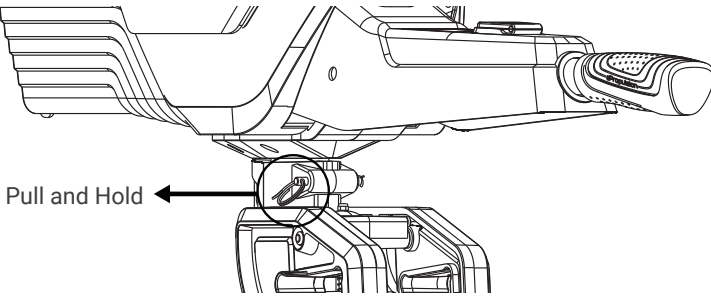

Figure 10-1

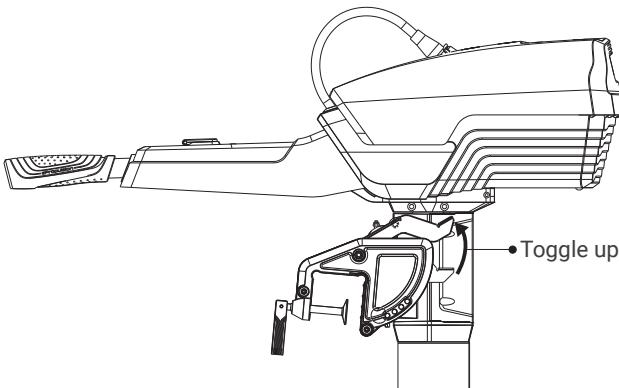

Figure 10-2

Step2: Release the beaching pin and the trim release lever will stay at the position shown in the figure below. And then the anti-grounding mode is activated.

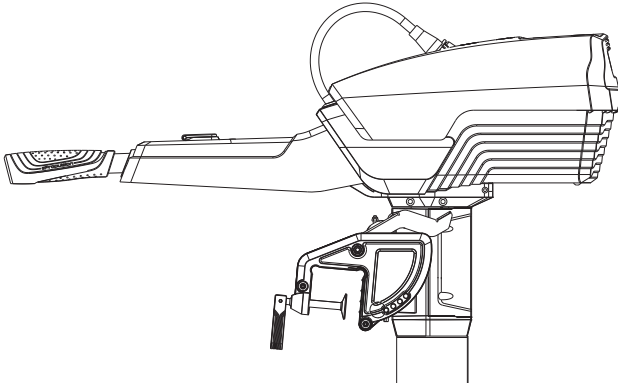





Figure 10-3

To inactivate the anti-grounding mode

Pull the beaching pin again and make the trim release lever return to horizontal position, the anti-grounding protection will be disabled and the outboard will work in normal state.

-  Never pull the trim release lever when the propeller is rotating.
-  Never activate the anti-grounding mode when the propeller is rotating.
-  Only use the anti-grounding mode in necessary conditions, such as in shallow water, near the shore or unknown underwater conditions.

11 Maintenance

11.1 Notes

Regular maintenance is beneficial to keep your outboard working in optimal condition.

Do not start the outboard in shallow or unknown water conditions. Only use the outboard in deep water area.

In order to clean and reduce corrosion, use fresh water to wash the whole outboard after use in salt water.

 Disconnect the battery from outboard before maintenance.

 Conduct the maintenance under instructions of professional experts or your dealer.

 Only use ePropulsion original components for replacement and maintenance.

11.2 Propeller Maintenance

 Ensure the battery is disconnected before each check, as a rotating propeller is dangerous.

 Gloves are recommended to wear, in order to protect your hand from the sharp propeller edges.

Check the propeller based on the following tips, then refer to the *9 Propeller Assembly* to replace a new propeller if necessary.

1. Check the propeller blades for wear broken and other damage.
2. Check the pin for wear and damage.
3. Check for water plants, fishing net or line twine around the propeller.

11.3 Replacing the Anode

Please refer to the figure below to replace a new anode if necessary.

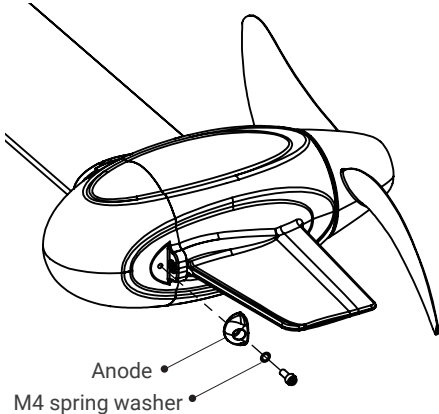

Figure 11-1

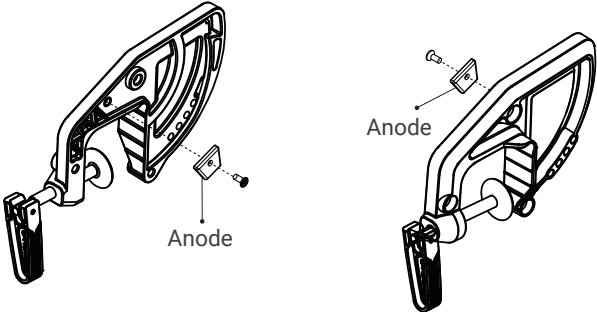

Figure 11-2

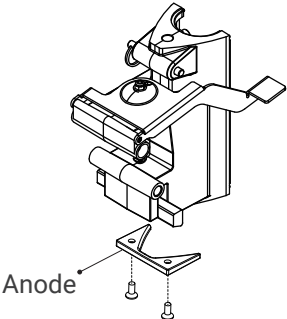

Figure 11-3

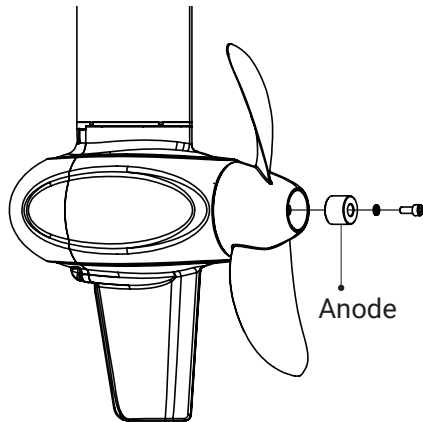

Figure 11-4

11.4 Maintenance Time Table

Regularly maintained in proper manner and used in normal condition, the outboard can work at its optimal state. The following table shows a general maintenance frequency, which however may vary according to operating conditions.

Item	Operations	Initial	Every	
		50 hours (3 months)	100 hours (6 months)	200 hours (12 months)
Anode	Check/Replace	□	□	■
Greasing points	Greasing		□	■
Propeller and pin	Check/Replace	□	□	■

💡 The "□" symbol indicates checks may be carried out by users. The "■" symbol indicates work to be carried out by your dealer.

Greasing Map

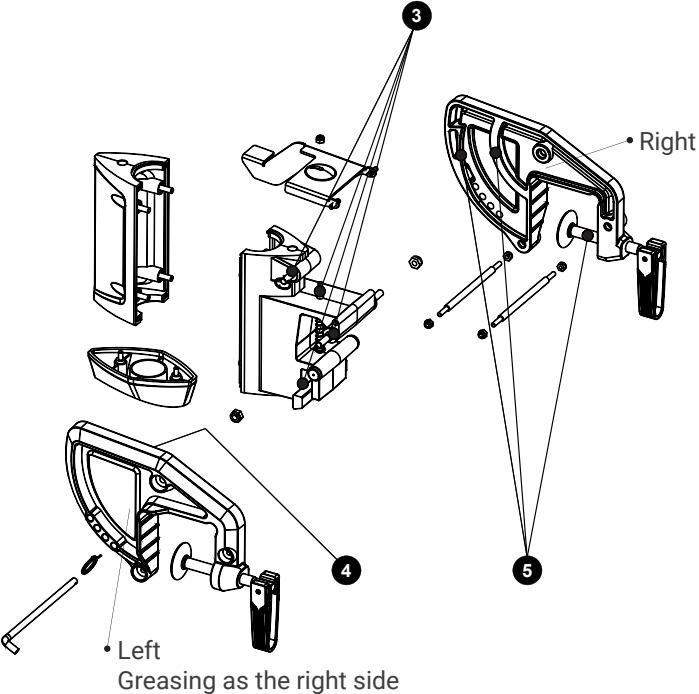
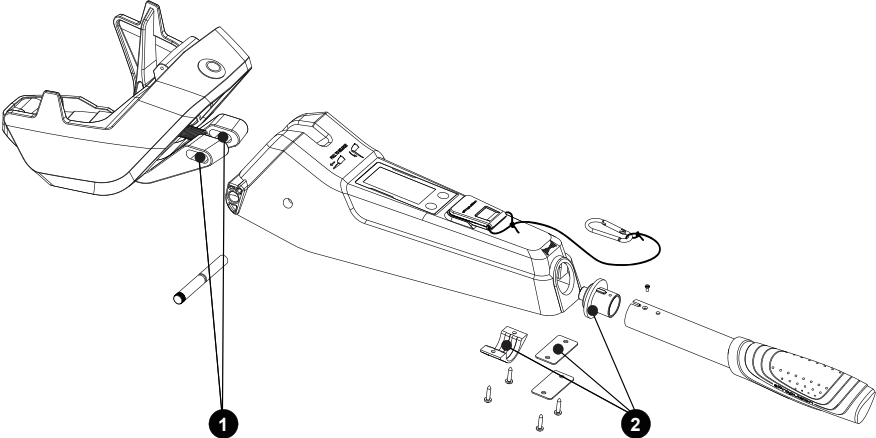

12 Transportation and Storage

12.1 Transportation

For long distance transport, please use the ePropulsion original package to pack the outboard before transportation.

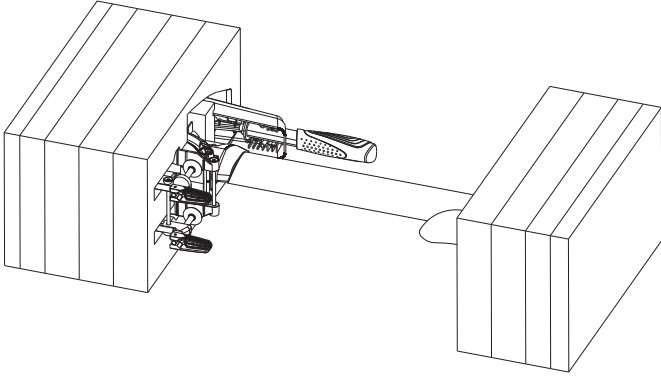

Figure 12-1

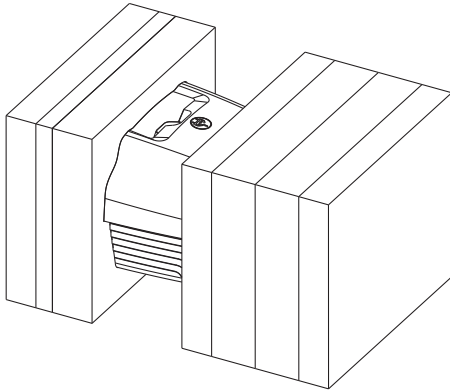

Figure 12-2

⚠ The Li-ion batteries higher than 100Wh are not allowed in the aircraft. The Li-ion batteries are classified under Class 9 (dangerous goods - see *Lithium Battery Guidance Document IATA 2015 Revision 1 – I-Site www.iata.org*).

⚠ Never ship a damaged or broken battery.

12.2 Placement

When place the outboard on the ground, ensure the ground is flat and clean. It's better to put some damping cotton or cushion under the outboard to prevent damage.

12.3 Storage

If your outboard is going to be stored for more than 2 months, it's advised to have the outboard cleaned, checked prior to storage. It's recommended to pack the outboard with ePropulsion original package for storage.



Take adequate damping-absorber for protection before transport and storage.

And ensure the propeller receives no pressure if the propeller is installed on the propeller shaft.



Store the outboard in a dry, well ventilated place without direct sun exposure.

13 Emergency Situations

13.1 Impact Damage

If the outboard strikes some object in the water, please follow the procedures below.

1. Stop the outboard immediately.
2. Check the propeller and other components before you start the motor again.
3. Return to the nearest harbor or beach.
4. If the motor is damaged, find your dealer or ePropulsion service center for help.

13.2 Submerged Outboard

If the outboard is submerged, stop it immediately and disconnect the battery. Ensure the outboard is thoroughly inspected before re-operation. Please contact your dealer for more information.

13.3 Low Battery Level

When the battery voltage is lower than a set threshold, the outboard will stop automatically to prevent battery from over-discharging. If this happens when the outboard is far away from the shore, and no new battery can be replaced, it's recommended to wait until the battery voltage recovers, and you can restart the outboard to return with throttle power under 100W.

14 Warranty

The ePropulsion limited warranty is provided for the first end purchaser of an ePropulsion product. Consumers are entitled to a free repair or replacement of defective parts or parts which do not conform with the sales contract. This warranty operates in addition to your statutory rights under your local consumer law.

14.1 Warranty Policies

ePropulsion warrants its products to be free of defects in material and workmanship for a limited period since the date of purchase. Once a fault is discovered, the user has the right to make a warranty claim under the ePropulsion warranty policies.

Product	Warranty Expiry Date
SPIRIT 1.0 Plus	Two years after the date of purchase.
Components have been repaired or replaced	Three months since the date of maintenance. Note: <ol style="list-style-type: none">1. If the three-month period overlaps with the original warranty period, the warranty against these replaced or repaired parts still expires two years after the date of purchase.2. If the three-month period exceeds the original warranty period, the repaired or replaced parts continue applying to warranty during the extended period.



In order to validate the warranty, users are required to fill in the Warranty Card in the package in advance.





Keep the product label in intact state and record the serial number on the label. Never tear the label off the product. An ePropulsion product without the original product label will not be applicable to warranty services provided by ePropulsion.



The warranty is valid only when the information is correct and complete.



Free warranty is only validated upon the presentation of legal serial number, Warranty Card, and evidence of purchase from an authorized ePropulsion dealer.

-  Valid date of purchase should be established by the first-hand purchaser with original sales slip.
-  Free warranty is not transferable and will not be reissued.
-  Within the limits of the applicable laws, the warranty policies of ePropulsion may update without prior notice. The latest version is available at our website www.epropulsion.com.

14.2 Out of Warranty

Make sure the product is properly packed during delivery, the original ePropulsion package is recommended. If the product got further damaged due to improper packing during delivery, the furtherly damaged part will be deemed as out of warranty coverage.

In addition, faults or damages caused by the following reasons are also excluded from warranty scope within the covered period:

- Any improper operation contradicts the user manual.
- Accident, misuse, wishful abuse, physical damage overcharging, liquid damage or unauthorized repair.
- Dropping, improper care or storage.

 You should be noted that minor faults like normal wear and tear that pose no influence on the intended function of the product are also not covered by the warranty.

 Consumables are out of warranty scope.

14.3 Warranty Claim Procedures

If you find your product defective, you can make a claim to your dealer following below procedures:

1. Fill in the Warranty Card correctly and completely in advance. Then make your warranty claim by sending it to your authorized ePropulsion service partner together with valid proof of purchase. Usually these documents are required when making a warranty claim: the Warranty Card, ex-factory serial number, and evidence of purchase.
2. Send the defective product to your authorized ePropulsion service point after getting the confirmation. Note that the label should be kept intact. You can

also deliver the product to your authorized ePropulsion dealer after getting confirmation.

3. The defective components or parts will be either repaired or replaced according to the diagnosis made by the ePropulsion authorized service partner.
 4. If your warranty claim is accepted, the equipment will be repaired or replaced free of charge. Note that any delivery cost incurred in the process is at your charge.
 5. After careful examination and confirmation by ePropulsion authorized dealer, the defective or faulty components will be repaired or replaced with brand new ones against the actual condition.
 6. In case your warranty claim be rejected, an estimated repair charge with round trip delivery cost will be sent for confirmation. ePropulsion authorized service point will conduct maintenance accordingly only after your confirmation.
-  If warranty expires, you can still enjoy maintenance services from authorized ePropulsion service partners with minimum maintenance charge.

Thanks for reading this user manual.

If you have any concerns or find any problems while reading, please don't hesitate to contact us. We are delighted to offer service for you.

Guangdong ePropulsion Technology Limited

Website: www.epropulsion.com

Email: service@epropulsion.com